



*GB1250 Series Ice Cuber
on a B950 Bin*

GB1250 | B950 ICE CUBER

UP TO 1,229 LB. DAILY CAPACITY

SIMPLICITY BY DESIGN

The KOLD-DRAFT 1250 Series Classic Ice Cuber produces up to 1,229 lbs. of ice per day. It is engineered with rugged unibody construction and its time-proven design ensures reliable operation, greater water efficiency and maximum ice-making capacity. Serviceability is from the front and the use of environmentally-friendly R-404A refrigerant gives greater efficiency.

The KOLD-DRAFT B950 Bin holds 950 lbs. of ice. The B950 has a polyethylene liner and stainless steel exterior front, sides and top. It is insulated with non-CFC foam for exceptional rigidity and optimum insulation. The B950 comes with an insulated stainless steel lift up door.



Full Cube
1 1/4" x 1 1/4" x 1 1/4"



Half Cube
1 1/4" x 5/8" x 1 1/4"



Cubelet
1 1/4" x 5/8" x 5/8"

KOLD-DRAFT®

THE HIGHEST QUALITY ICE

Ice that's free from impurities. Ice that's uniformly shaped ensuring maximum displacement and ease of handling. Ice that sparkles, melts slowly and looks like ice should look. Three sizes of KOLD-DRAFT cubes to choose from that meet your exact needs. Full cubes, half cubes and cubelets – the highest quality ice.

STACKABILITY

GB Series Classic Ice Cubers are stackable with each other and can be stacked on existing KOLD-DRAFT GB Series Classic and Electronic Cubers. This unique "Add-A-Unit" feature will give you unsurpassed flexibility in ice-making capacity. So as your business grows, so can your ice capacity without using valuable floor space.

KOLD-DRAFT'S WARRANTY

KOLD-DRAFT'S Warranty provides five years parts and labor on the entire machine and five years on the compressor and evaporator parts. See KOLD-DRAFT'S Warranty Statement for details.

GB1250 | B950

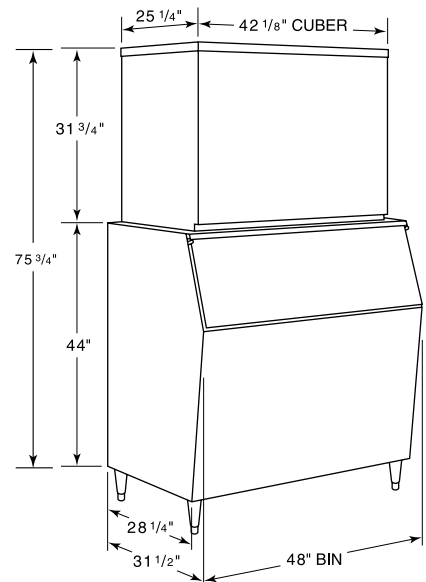

*GB1250 on a B950 Bin. Stores 950 lbs. of ice,
based on 35 lbs./cu.ft. at 90% of bin volume.*

